

OPERATING INSTRUCTIONS AND OWNER'S MANUAL

MR. HEATER

READ INSTRUCTIONS CAREFULLY: Read and follow all instructions. Place instructions in a safe place for future reference. Do not allow anyone who has not read these instructions to assemble, light, adjust or operate the heater.

HEATSTAR

MODEL
MHU 45
MHU 75

MODEL
HSU 45
HSU 75

COMPACT UNIT HEATER

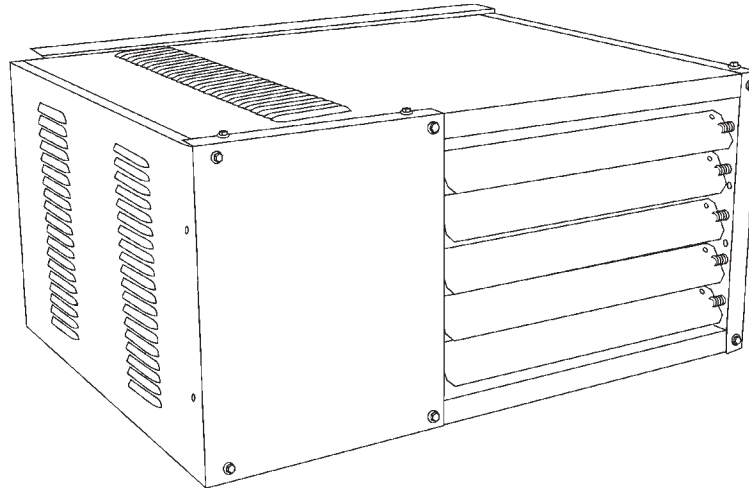

WARNING: Improper installation, adjustment, alteration, service or maintenance can cause injury or property damage. Refer to this manual. For assistance or additional information consult a qualified installer, service agency or the gas supplier.

— WHAT TO DO IF YOU SMELL GAS

- Open Windows
- DO NOT try to light any appliance.
- DO NOT use electrical switches.
- DO NOT use any telephone in your house. Immediately call your local gas supplier from a neighbor's telephone. Follow the gas supplier's instructions.
- Do not touch any electrical switch; do not use any phone in your building.
- Installation and service must be performed by a qualified installer, service agency or the gas supplier.
- If you cannot reach your gas supplier, call the Fire Department.

FOR YOUR SAFETY:

Do not store or use gasoline or other flammable vapors and liquids in the vicinity of this or any other appliance.

WARNING: If the information in these instructions are not followed exactly, a fire or explosion may result causing property damage, personal injury or loss of life.

WARNING:

- ⚠ YOUR SAFETY IS IMPORTANT TO YOU AND TO OTHERS, SO PLEASE READ THESE INSTRUCTIONS BEFORE YOU OPERATE THIS HEATER.

GENERAL HAZARD WARNING:

- ⚠ FAILURE TO COMPLY WITH THE PRECAUTIONS AND INSTRUCTIONS PROVIDED WITH THIS HEATER, CAN RESULT IN DEATH, SERIOUS BODILY INJURY AND PROPERTY LOSS OR DAMAGE FROM HAZARDS OF FIRE, EXPLOSION, BURN, ASPHYXIATION, CARBON MONOXIDE POISONING, AND/OR ELECTRICAL SHOCK.
- ⚠ ONLY PERSONS WHO CAN UNDERSTAND AND FOLLOW THE INSTRUCTIONS SHOULD USE OR SERVICE THIS HEATER.
- ⚠ IF YOU NEED ASSISTANCE OR HEATER INFORMATION SUCH AS AN INSTRUCTIONS MANUAL, LABELS, ETC. CONTACT THE MANUFACTURER.

WARNING:

- ⚠ FIRE, BURN, INHALATION, AND EXPLOSION HAZARD. KEEP SOLID COMBUSTIBLES, SUCH AS BUILDING MATERIALS, PAPER OR CARDBOARD, A SAFE DISTANCE AWAY FROM THE HEATER AS RECOMMENDED BY THE INSTRUCTIONS NEVER USE THE HEATER IN SPACES WHICH DO OR MAY CONTAIN VOLATILE OR AIRBORNE COMBUSTIBLES, OR PRODUCTS SUCH AS GASOLINE, SOLVENTS, PAINT THINNER, DUST PARTICLES OR UNKNOWN CHEMICALS.

WARNING:

- ⚠ **The State of California requires the following warning:** COMBUSTION BY-PRODUCTS PRODUCED WHEN USING THIS PRODUCT CONTAIN CARBON MONOXIDE, A CHEMICAL KNOWN TO THE STATE OF CALIFORNIA TO CAUSE CANCER AND BIRTH DEFECTS (OR OTHER REPRODUCTIVE HARM).

CONTENTS

UNIT DIMENSIONS	3
SHIPPING	4
REQUIREMENTS	4
UNIT HEATER INSTALLATION	5
COMBUSTION & VENTILATION AIR	5
VENTING	5
ELECTRICAL CONNECTIONS	8
GAS CONNECTION	8
LEAK CHECK	9
START-UP OPERATION	9
HEATING SEQUENCE OF OPERATION	10
IGNITION CONTROL LED	11
ADJUSTMENTS	11
SERVICE	12
WIRING DIAGRAM	13
PARTS LIST	14
WARRANTY	16

MHU45/MHU75 AND HSU45/HSU75 UNIT DIMENSIONS

(N-NATURAL GAS, P-PROPANE)

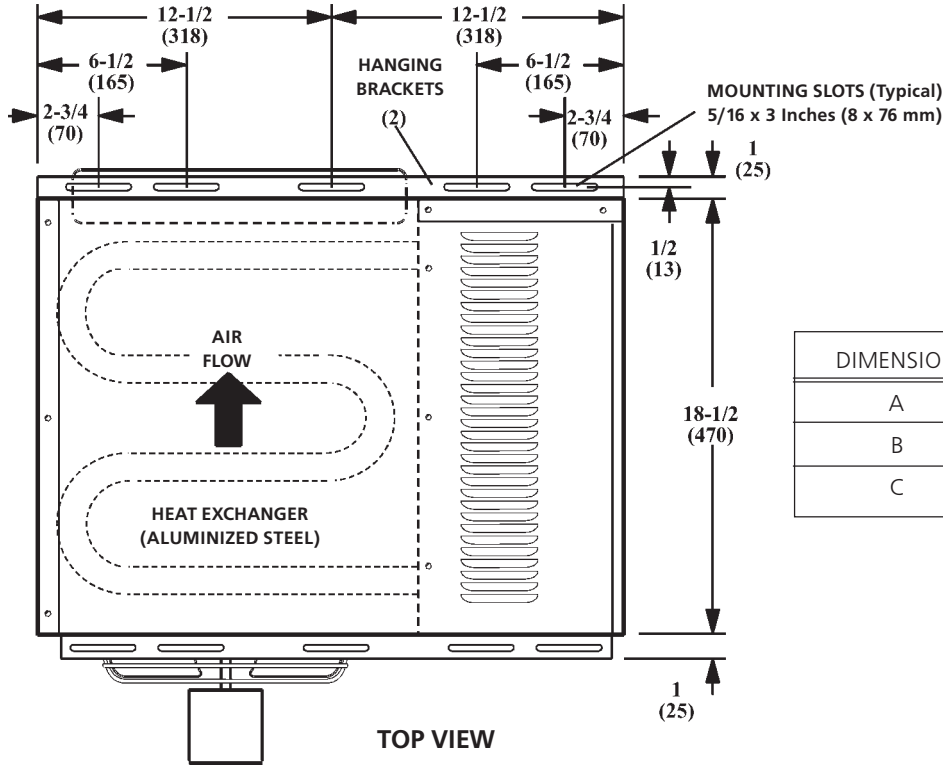

DIMENSION	45	75
A	12 (305)	17 (432)
B	5-1/2 (140)	6-1/2 (165)
C	4-1/4 (108)	6-3/4 (171)

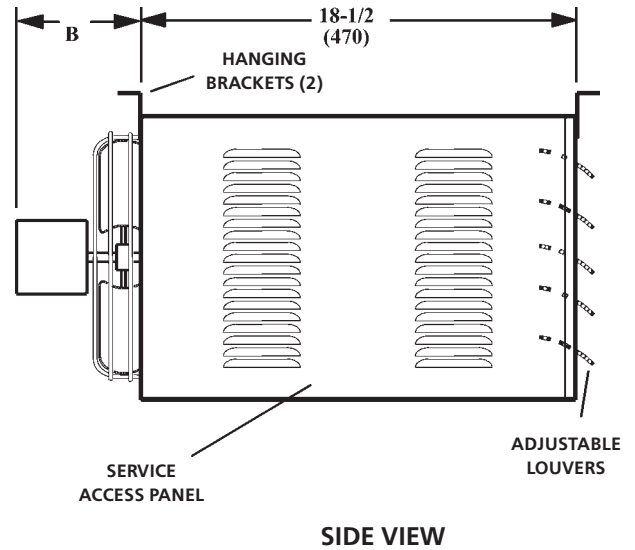
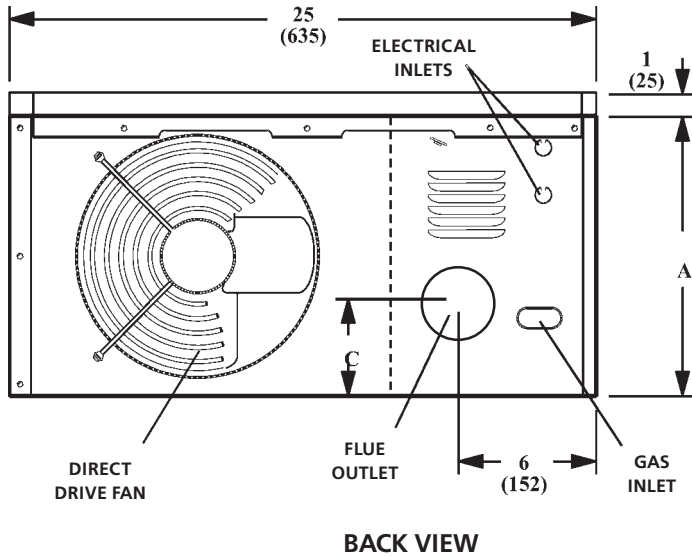

START-UP AND PERFORMANCE CHECK LIST

Job Name: _____ Job No.: _____ Date: _____
 Job Location: _____ City: _____ State/Province: _____
 Installer: _____ City: _____ State/Province: _____
 Unit Model No.: _____ Serial No.: _____ Service Technician: _____

Electrical Connections Tight? _____ Flue Connections Tight? _____
 Supply Voltage _____ Fan Timer Operation Checked? _____
 Gas Piping Connections Tight & Leak-Tested? _____ THERMOSTAT _____
 Motor Amps _____ Calibrated? _____
 Furnace Btu Input _____ Heat Anticipator Properly Set? _____
 Line Pressure _____ Level? _____
 Manifold Pressure w.c. _____

SHIPPING

The heater is completely assembled. Installation instructions, two mounting brackets (shipped loose), and a flue transition are included. Check the unit for shipping damage. The receiving party should contact the last carrier immediately if any shipping damage is found.

REQUIREMENTS – CSA IN THE USA

Installation of gas unit heaters must conform with local building codes or, in the absence of local codes, with the current National Fuel Gas Code ANSI Z223.1.

Installation in aircraft hangers must be in accordance with the current Standard for Aircraft Hangers ANSI/NFPA No. 409.

Installation in parking structures must be in accordance with the current Standard for Parking Structures ANSI/NFPA No. 88A.

Installation in repair garages must be in accordance with the current Standard for Repair Garages ANSI/NFPA No. 88B.

These units are approved for residential applications. For installation in a residential garage these units must be installed so that burners and ignition source are located no less than 18" (457mm) above floor. Heater must be located or protected to avoid physical damage by vehicles. Refer to the National Fuel Gas Code, ANSI Z223.1, current edition.

Authorities having jurisdiction should be consulted before NFPA installation. Air for combustion and ventilation must conform to the methods outlined in ANSI Z223.1, section 5.3, Air for Combustion and Ventilation, or applicable provisions of local building codes. The National Fuel Gas Code is available from:

American National Standard Institute Inc.
11 West 42nd Street
New York, NY 10036

These units are CSA International design certified. These unit heaters are certified for installation to combustible material as listed in table 1 and on unit rating plate. Accessibility and service clearances must be observed in addition to fire protection clearances.

All electrical wiring and ground for unit must be in accordance with the regulations of the current National Electric Code ANSI/No. 70.

The National Electric Code is available from:

National Fire Protection Association
1 Batterymarch Park
PO Box 9101
Quincy, MA 02269-9101

**TABLE 1
UNIT CLEARANCES**

Top		Sides		Access Panel	
in	mm	in	mm	in	mm
1	25	1	25	18	457
Bottom		Rear		Single Wall Vent*	
in	mm	in	mm	in	mm
0	0	18	456	6	152
*Except for listed clearance thimbles.					

REQUIREMENTS – CSA IN CANADA

The instructions are intended only as a general guide and do not supersede local codes in any way. Authorities having jurisdiction should be consulted before installation. The installation must conform with local building codes or in the absence of local codes, with the current CSA B149.1, Natural Gas and Propane Installation Code. All electrical wiring and grounding for the unit must also comply with the Canadian Electrical Code CSA C22.1, current edition.

These unit heaters are CSA International, certified for the clearances to combustible material listed on the rating plate and **table 1**. Adequate clearance around air openings into the combustion chamber, clearances from combustible material, and provisions for accessibility and for combustion and ventilation air supply. Provision shall be made for service accessibility to the heater. Note that fire protection clearances may be exceeded to provide additional space for service and accessibility.

GARAGE INSTALLATIONS:

Installation in parking structures must be in accordance with the current Standard for Parking Structures ANSI/NFPA No. 88A.

Installation in repair garages must be in accordance with the current Standard for Repair Garages ANSI/NFPA No. 88B.

1. In a storage area, clearance from heaters to combustible materials must be such that the material shall not attain a temperature above 160°F by continuous operation of the unit.
2. Eight foot minimum clearance from the floor to the bottom of the heater must be maintained. Refer to the CSA B149.1, Natural Gas and Propane Installation Code

AIRCRAFT HANGER:

Installation of gas unit heaters must conform with local building codes or, in the absence of local codes, with the current National Fuel Gas Code ANSI Z223.1.

1. In an area where aircraft are housed or serviced, 10' minimum clearance from highest surface of aircraft to bottom of the heater must be maintained.
2. In other areas, 8' minimum clearance from the floor to bottom of heater must be maintained.
3. Heaters should be located so as to be protected from damage from aircraft or other appliances needed for servicing of aircraft. Refer to requirements of the enforcing authorities.

These units are approved for residential applications. For installation in a residential garage, these units must be installed so that burners and ignition source are located no less than 18" (457mm) above floor. Heater must be located or protected to avoid physical damage by vehicles. Refer to CSA B149.1, Natural Gas and Propane Installation Code current edition.

In a confined area, the heater must be installed in accordance with the CSA B149.1, Natural Gas and Propane Installation Code. Be sure to check with local codes and ordinances for additional requirements.

UNIT HEATER INSTALLATION

The installation shall conform with local building codes or, in the absence of local codes, with the **National Fuel Gas Code, ANSI Z223.1 / NFPA 54** or the **CSA B 149.1, Natural Gas and Propane Installation Code**.

The appliance and venting system is to be inspected once a year by a qualified service agency.

Unit is shipped ready for installation. Unit may be installed as shown in figure 1 or inverted 180° depending on desired location as governed by clearances, vent connection, air direction, gas supply, electrical supply and service accessibility.

1. If installing unit in an inverted position: Remove and retain screws securing door and rotate door 180°. Secure with retained screws. Rotate louvers directing airflow as desired.
2. Choose location for mounting brackets.
3. Remove and retain three screws along top edge (bottom edge when inverted) of front of unit.
4. Align screw holes on mounting bracket with holes along top edge (either upright or inverted) of unit. Secure one mounting bracket to front of unit with retained screws. Secure other mounting bracket to back of unit with screws provided in bag assembly containing flue transition.
5. To support unit, secure mounting bracket to ceiling joist or truss. Unit may also hang on rods as shown in figure 1.

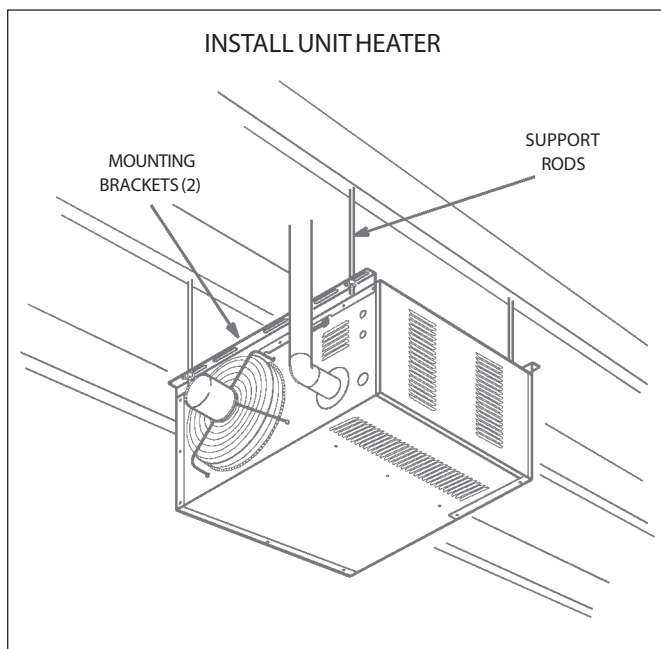

FIGURE 1

COMBUSTION AND VENTILATION AIR

Adequate facilities for supplying air for combustion and ventilation must be provided in accordance with the latest edition of section 5.3, Air for Combustion and Ventilation, of the National Fuel Gas Code, ANSI Z223.1, in the U.S.A., CSA B149.1 Natural Gas and Propane Installation Code in Canada, or applicable provisions of local building codes.

All gas fired appliances require air to be used for the combustion process. In many buildings today, there is a negative indoor air pressure caused by exhaust fans, etc. If sufficient quantities of combustion air are not available, the heater or another appliance will operate in an inefficient manner, resulting in incomplete combustion which can result in the production of excessive carbon monoxide.

CAUTION Insufficient combustion air can cause headaches, nausea, dizziness, asphyxiation or death.

If indoor air is to be used for combustion, it must be free of the following substances or the life of the heat exchanger will be adversely affected: chlorine, carbon tetrachloride, cleaning solvent, halogen refrigerants, acids, cements and glues, printing inks, fluorides, paint removers, varnishes, or any other corrosives.

VENTING

A – GENERAL RECOMMENDATIONS AND REQUIREMENTS

NOTE: The vent is a passageway, vertical or nearly so, used to convey flue gases from an appliance, or its vent connector, to the outside atmosphere. The vent connector is the pipe or duct that connects a fuel-gas burning appliance to a vent or chimney.

Unit heaters must be vented in compliance with all local codes or requirements of the local utility, the current standards of the (American) National Fuel Gas Code, ANSI Z223.1 or (Canada) CSA B149.1 Natural Gas and Propane Installation Code, and the following instructions.

A metal stamped/extruded transition is supplied with this certified unit. It must not be modified or altered and must be installed on the outlet of the induced draft blower assembly prior to the installation of the vent or vent connector. Failure to comply with this requirement will void the certification of the unit by the approval agencies. All joints shall be secured with at least two corrosion resistant screws. All joints must be checked for gas tightness after installation.

TABLE 2
MAXIMUM VENT LENGTHS
HORIZONTAL VENTS

No. of Elbows	ft	m
1	25	7.6
2	20	6.1
3	15	4.6
4	10	3.0
5	5	1.5
Maximum length of vent connector not to exceed 30 ft. (9.1 m).		

B – VERTICAL VENTS USING METAL VENT PIPE – COMMERCIAL AND RESIDENTIAL INSTALLATIONS

MHU/HSU compact unit heaters are listed as Category I appliances for vertical vent installations.

- MHU/HSU unit heaters are to be used with NFPA- or ANSI-approved chimneys, U.L. listed type B-1 gas vents, single wall metal pipe, or listed chimney lining system for gas venting where applicable, as well as the modifications and limitations listed in figure 2. Seal single wall vent material according to the section A - General Recommendations and Requirements.
- The vent connector shall be 3" (76mm) diameter on 45 unit and 4" (100mm) diameter for the 75 unit. In all cases, a flue transition piece (supplied) is required to fit over the outlet of the induced draft assembly on the appliance.
- Keep the vent connector runs as short as possible with a minimum number of elbows. Refer to the (American) National Fuel Gas Code ANSI Z223.1 or (Canada) CSA B149.1 Natural Gas and Propane Installation Code for maximum vent and vent connector lengths. Horizontal run of the vent connector from the induced draft blower to the chimney/vent cannot exceed the values in table 2.
- When the length of a single wall vent, including elbows, exceeds 5 feet (1.5m), the vent shall be insulated along its entire length with a minimum of 1/2" thick foil faced fiberglass 1-1/2# density insulation. If a single wall vent is used in an unheated area it shall be insulated. Failure to do so will result in condensation of flue gases.
- The unit may be vented vertically as a single appliance or as a common vent with other gas-fired appliances. In common venting situations, vent connectors for other appliances must maintain a 4" (100mm) vertical separation between the vent connectors. Refer to common venting tables in the (American) National Fuel Gas Code ANSI Z223.1 or (Canada) CSA B149.1 Natural Gas and Propane Installation Code for proper vent size.
- Clearance to combustible material is 6" (152mm) for single wall vent material except where a listed clearance thimble is used. Clearance to combustible material for type B-1 vent or factory-built chimney is per manufacturer's instructions.
- The vent connector shall be supported without any dips or sags. Vertical vents shall be supported in accordance with their listing and manufacturers' instructions. All horizontal vent connector runs shall have a slope up to the vertical vent of at least 1/4" per foot (1mm per 50mm).
- All vertical type B-1 vents, single wall vents, or listed chimney lining system must be terminated with a listed ventcap or listed roof assembly.
- The vent must extend at least 3' (1m) above the highest point where it passes through a roof of a building and at least 2' (0.6m) higher than any part of a building within a horizontal distance of 10' (3.05m) unless otherwise specified by the (American) National Fuel Gas Code, ANSI Z223.1 or (Canada) CSA B149.1 Natural Gas and Propane Installation Code. The vent must extend at least 5' (1.6m) above the highest connected equipment flue collar.

C – HORIZONTAL VENTING – GENERAL

Common venting is not allowed when horizontally venting the unit heater.

The minimum horizontal vent length is three feet (914mm).

- If possible, do not terminate the horizontal vent through a wall that is exposed to prevailing wind. Exposure to excessive winds can affect unit performance. If such a termination is necessary, use a wind block to protect the vent termination from direct wind.
- Vent termination must be free from obstructions and at least 12" (306mm) above grade level and maximum snow height.

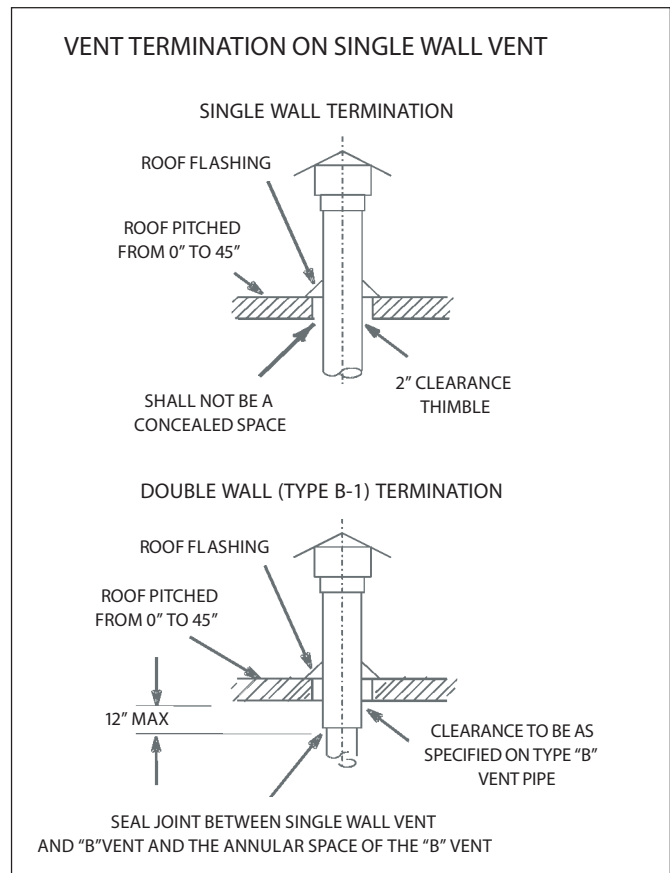

FIGURE 2

- Do not terminate vent directly below roof eaves or above a walkway, or any other area where condensate dripping may be troublesome and may cause some staining. Avoid windows where steam may cause fogging or ice buildup.
- When horizontally vented, minimum clearance for termination from any door, window, gravity air inlet, gas or electric meter, regulators, and relief equipment is 4 ft. (1.2m) for U.S. installations. Refer to NFPA 54/ANSI Z223.1 in the U.S.A. and CSA B149.1 Natural Gas and Propane Installation Code in Canada or with authorities having local jurisdiction. In Canada, vent termination must have a minimum 6 ft. (1.8m) horizontal clearance from gas and electric meters and relief devices as specified in the CSA B149.1, Natural Gas and Propane Installation Code.

5. Vent termination must be a minimum of 4' (1.2m) below or 4' (1.2m) horizontally from any soffit vent or under-eave vent.
6. Vent must be a minimum of 6' from an inside corner formed by two exterior walls. If possible, leave a 10' clearance.
7. Vent termination must be a minimum of 10' (3m) from any forced air inlet (includes fresh air inlet for other appliances, such as a dryer).
8. When termination is routed through an exterior combustible wall the vent must be supported using a listed clearance thimble. Where local authorities permit, a single section of type B-1 vent pipe may be used as an alternative to the thimble. When using a type B-1 vent termination use the clearances specified by the vent manufacturer. Seal the connection between the single wall and double wall pipes and the annular space of the double wall pipe as shown in figure 2. Inside edge of vent termination tee must be at least 12 inches from outside wall as shown in figure 3 .
9. For horizontal venting, the vent pipe shall be supported with hangers no more than 3ft. (1m) apart to prevent movement after installation.

D – HORIZONTAL VENTING – COMMERCIAL

1. Horizontal commercial installations are for buildings which are not attached to living spaces. The vent may be single wall vent material installed according to the sections Venting A - General Recommendations and Requirements and C - Horizontal Venting General and D - Horizontal Venting - Commercial. Refer to figure 3.
2. The vent pipe diameter for horizontal commercial installations shall be 4" (101mm) on the 45 and 75 units. In all cases a flue transition piece (supplied) is required to fit over the outlet of the induced draft assembly on the appliance.

3. Refer to table 2 for maximum vent connector lengths.
4. Select a wall termination point that will maintain 1/4" rise per foot slope of horizontal run of vent pipe. The vent may be single wall material minimum 26 GSG (0.46mm) galvanized steel or equivalent grade stainless steel. Seal single wall vent material according to the section A - General Recommendations and Requirements.
5. For upward sloped vent a condensate tee and drain must be installed within the first 5' (1.5m) from the unit heater to protect the appliance. If a flexible condensate drain line is used, the drain line must include a loop entering the structure. If the unit is shut down for an extended period of time and will be exposed to sub-freezing temperatures, the condensate may freeze.

E – HORIZONTAL VENTING – RESIDENTIAL

1. For horizontal residential installations these units are certified as Category I appliances. The vent may be single wall material minimum 25 GSG (0.46mm) galvanized steel or equivalent grade stainless steel. Venting A - General Recommendations and Requirements and C - Horizontal Venting General and E - Horizontal Venting - Residential. Refer to figure 6 .
2. The vent pipe diameter for horizontal residential installations shall be 4" (101 mm) on both 45 and 75 units. A standard vent transition is required at unit in addition to the transition supplied with the unit.
3. The maximum vent length is 5' (1.5m) plus one 90-degree elbow.
4. The vent must maintain a 1/4" rise per foot of slope upwards toward the termination.

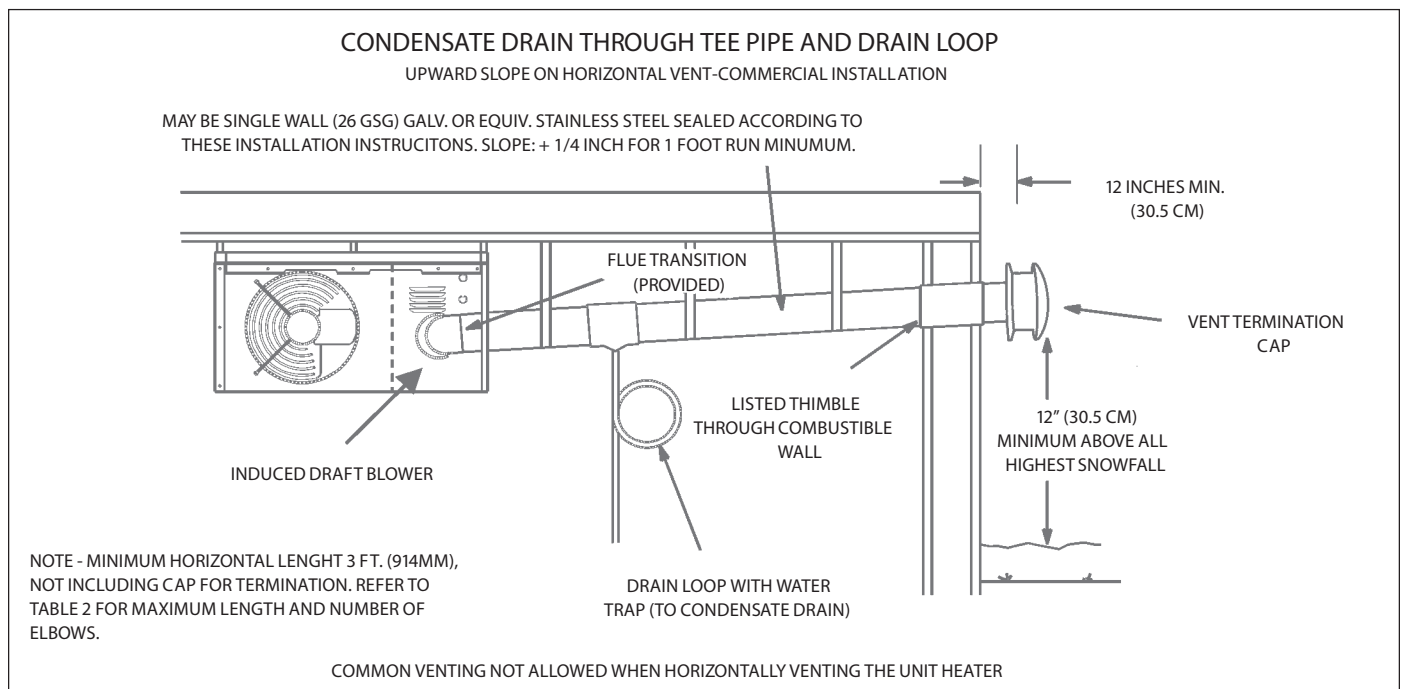

FIGURE 3

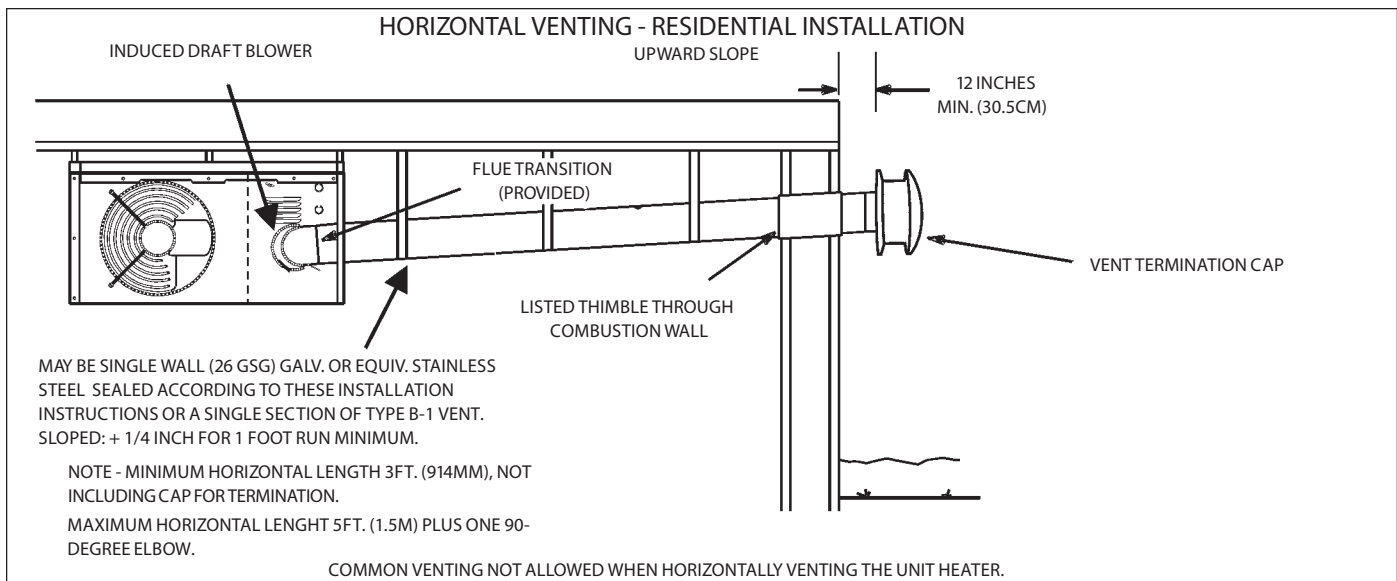

FIGURE 6

F – VENTING USING A MASONRY CHIMNEY

The following additional requirements apply when a lined masonry chimney is being used to vent the compact unit heater.

1. Masonry chimneys used to vent Category I units heaters must be either tile-lined or lined with a listed metal lining system or dedicated gas vent. Unlined masonry chimneys are prohibited. A category I appliance must never be connected to a chimney that is servicing a solid fuel appliance. If a fireplace chimney flue is used to vent this appliance, the fireplace opening must be permanently sealed.
2. A fan assisted unit heater may be commonly vented into an existing lined masonry chimney provided:
 - The chimney is currently serving at least one draft-hood equipped appliance.
 - The vent connector and chimney are sized in accordance with venting tables in the (American) National Fuel Gas Code ANSI Z223.1 or (Canada) CSA B149.1 Natural Gas and Propane Installation Code.

IMPORTANT Single appliance venting of a fan assisted unit heater into a tile lined masonry chimney (interior or outside wall) is prohibited. The chimney must first be lined with either type B-1 vent or an insulated single wall flexible vent lining system, sized in accordance with venting tables in the (American) National Fuel Gas Code ANSI Z223.1 or (Canada) CSA B149.1 Natural Gas and Propane Installation Code.

3. A type B-1 vent or masonry chimney liner shall terminate above the roof surface with a listed cap or a listed roof assembly in accordance with the terms of their respective listings and the vent manufacturer's instructions.
4. Do not install a manual damper, barometric draft regulator, or flue restrictor between the unit heater and the chimney.
5. If type B-1 double-wall vent is used inside a chimney, no other appliance can be vented into the chimney. Outer wall of type B-1 vent pipe must not be exposed to flue products.
6. Insulation for the flexible vent pipe must be an encapsulated fiberglass sleeve recommended by the flexible vent pipe manufacturer.

7. The space between liner and chimney wall should NOT be insulated with puffed mica or any other loose granular insulating material.
8. If type B-1 vent or an insulated flexible vent pipe cannot be used as liners, the chimney must be rebuilt to accommodate one of these methods or some alternate approved method must be found to vent the appliance. When inspection reveals that an existing chimney is not safe for the intended purpose, it shall be rebuilt to conform to nationally recognized standards, lined or relined with suitable materials or replaced with a gas vent or chimney suitable for venting unit heaters. The chimney passageway must be checked periodically to ensure that it is clear and free of obstructions.

G – REMOVAL OF UNIT FROM COMMON VENT

In the event that an existing unit heater is removed from a venting system commonly run with separate gas appliances, the venting system is likely to be too large to properly vent the remaining attached appliances. The following test should be conducted while each appliance is in operation and the other appliances are not in operation, yet remain connected to the common venting system. If the venting system has been installed improperly, the system must be corrected.

1. Seal any unused openings in the common venting system.
2. Visually inspect the venting system for proper size and horizontal pitch. Determine there is no blockage or restriction, leakage, corrosion, or other deficiencies which could cause an unsafe condition.
3. In so far as is practical, close all building doors and windows and all doors between the space in which the appliances remaining connected to the common venting system are located and other spaces of the building. Turn on clothes dryers and any appliances not connected to the common venting system. Turn on any exhaust fans, such as rangehoods and bathroom exhausts, so they will operate at maximum speed. Do not operate a summer exhaust fan. Close fireplace dampers.
4. Follow the lighting instructions. Place the appliance being inspected in operation. Adjust thermostat so appliance will operate continuously.

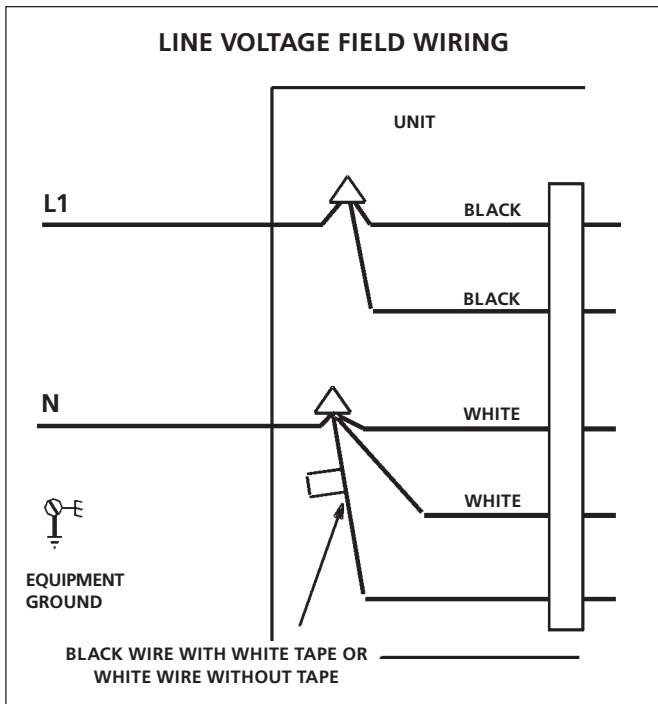

5. Test for spillage at the draft hood relief opening after five minutes of main burner operation. Use the flame of a match or candle, or smoke from a cigarette, cigar, or pipe.
6. After it has been determined that each appliance remaining connected to the common venting system properly vents when tested as outlined above, return doors, windows, exhaust fans, fireplace dampers and any other gas-burning appliance to their previous condition of use.
7. If improper venting is observed during any of the above tests, the common venting system must be corrected. The common venting system should be resized to approach the minimum size as determined by using the appropriate tables in Appendix G in the current standards of the National Fuel Gas Code, ANSI Z223-1 in the U.S.A. and the appropriate Category I Natural Gas and Propane appliances venting sizing tables in the current standards of the CSA B149.1 Natural Gas and Propane Installation Code in Canada.

NOTE Local codes may supersede any of the above provisions.

ELECTRICAL CONNECTIONS

NOTE The MHU/HSU series unit heaters use a direct spark ignition system. There is no pilot necessary as the spark lights the main burner as the gas valve is turned on. The direct spark ignition

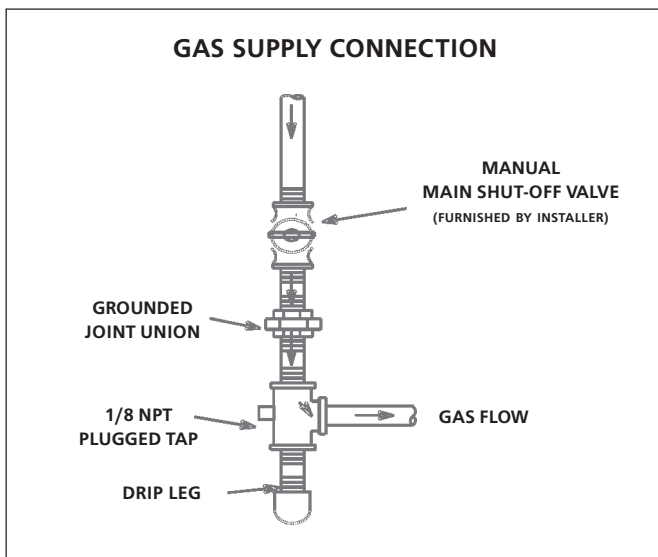

	WARNING
	<p>Electric shock hazard. Can cause injury or death. Do not use this heater if any part has been under water. Immediately call a qualified service technician to inspect the furnace and to replace any part of the control system and any gas control which has been under water.</p>

	WARNING
	<p>Danger of explosion. Can cause injury or product or property damage. If overheating occurs or if gas supply fails to shut off, shut off the manual gas valve to the appliance before shutting off electrical supply.</p>

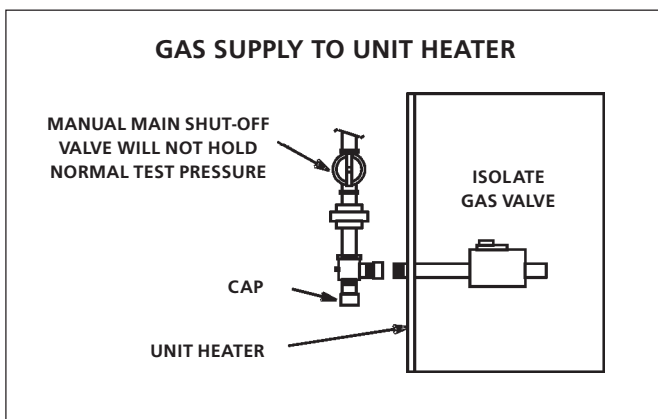

	WARNING
	<p>Electric shock hazard. Can cause injury or death. Before attempting to perform any service or maintenance, turn the electrical power to unit OFF at disconnect switch(es). Unit may have multiple power supplies.</p>

	WARNING
	<p>Danger of explosion and fire. Can cause injury or product or property damage. You must follow these instructions exactly.</p>

control board emits radio noise as the sparking process is underway. The level of energy may be sufficient to disturb a logic circuit in a microprocessor controlled thermostat. It is recommended that an isolation relay be used when connecting the unit heaters to a microprocessor controlled thermostat. Install the thermostat according to instructions provided. Select circuit protection and wire size according to the unit rating plate. Install a separate disconnect switch (protected by either fuse or circuit breaker) near the unit so that power can be turned off for servicing. Connect wiring through knockout on the junction box located on the side of the unit heater. Refer to heater wiring diagram for connection information. Use 18 gauge wire or larger for thermostat connections.

Electrically ground unit in accordance with local codes or, in the absence of local codes, in accordance with the current National Electrical Code (ANSI/NFPA No. 70) in the U.S.A., and in Canada with the current Canadian Electrical Code, Part 1 CSA C22.1.

NOTE Uninsulated ground wires must be wrapped in electrical tape to avoid damage to the electrical system.

Make line voltage connections as shown in figure 7 . Connect field wiring as shown on wiring diagram on unit. Also refer to typical diagram in this manual. An additional thermostat wire must be run to terminal "G" on heater when continuous blower is desired.

GAS CONNECTION

When connecting gas supply, the length of the run from the meter must be considered in determining the pipe size to avoid excessive pressure drop. A line pressure of 7" w.c. (178mm w.c.) for natural gas should be maintained when sizing piping. A line pressure of 13" w.c. (330mm w.c.) should be maintained for liquefied petroleum (LP) gas. For correct sizing of piping, refer to the (American) National Fuel Gas Code ANSI Z223.1 or (Canada) CSA B149.1, Natural Gas and Propane Installation Code or consult the utility having jurisdiction.

A drip leg should be installed in the vertical pipe run to the unit. In some localities, codes may require that a manual main shutoff valve and union (furnished by installer) be installed external to the unit. Union must be of the ground joint type. A drip leg should be readily accessible to permit cleaning and emptying. See figure 8 .

NOTE If a switch box is mounted over electrical knockouts on back of unit, leave a minimum of 4" (102mm) clearance between switch box and drip leg.

A 1/8" NPT plugged tap shall be installed immediately upstream of the gas supply connection to the heater.

NOTE Compounds used on threaded joints of gas piping must be resistant to the actions of liquefied petroleum gases.

LEAK CHECK

After gas piping is completed, carefully check all piping connections, (field and factory), for gas leaks. Use a soap solution or other preferred means.

CAUTION DO NOT use matches, candles, flame or other sources of ignition to check for gas leaks.

IMPORTANT The heater and its individual shut off valve must be

disconnected from the gas supply piping system during any pressure testing of that system at test pressures in excess of 1/2 psig (3.45kPa).

The appliance must be isolated from the gas supply piping system by closing its individual manual gas shutoff valve during any pressure testing of the gas supply system at test pressures equal to or less than 1/2 psig (3.45kPa). See figure 9 .

NOTE In case emergency shutdown is required, shut down main gas valve and disconnect main power to unit. These devices should be properly labeled by the installer.

START – UP AND OPERATION

UNIT START-UP

FOR YOUR SAFETY READ BEFORE LIGHTING

BEFORE LIGHTING smell all around the appliance area for gas. Be sure to smell next to the floor because some gas is heavier than air and will settle on the floor.

Use only your hand to push in or turn the gas control knob. Never use tools. If the knob will not push in or turn by hand, do not try to repair it, call a qualified service technician. Force or attempted repair may result in a fire or explosion.

MHU45/75 and HSU 45/75 unit heaters are equipped with an automatic spark ignition system. There is no pilot. In case of a safety shutdown, move thermostat switch to OFF, then return the thermostat switch to HEAT position.

Should overheating occur, or the gas supply fail to shut off, shut off the manual gas valve to the appliance before shutting off the electrical supply.

GAS VALVE OPERATION FOR ROBERTSHAW 2000 DER SERIES VALVE (FIGURE 10)

1. **STOP!** Read the safety information at the beginning of this section.
2. Set the thermostat to lowest setting.
3. Turn off all electrical power to appliance.
4. This appliance is equipped with an ignition device which automatically lights burner. **DO NOT** attempt to light the burners manually.
5. Depress knob on gas valve; knob will snap to OFF. (See Figure 10)
6. Wait five minutes to clear out any gas. If you then smell gas, **STOP!** Immediately call your gas supplier from a neighbor's phone. Follow the gas supplier's instructions. If you do not smell gas go to next step.
7. Turn knob on gas valve 90 ° counterclockwise to ON.
8. Turn on electrical power to unit.
9. Set the thermostat to desired setting.
10. The combustion air blower will start. The burners will light within 40 seconds.
11. If unit does not light first time (gas line not fully purged) it will attempt up to two more ignitions before locking out.
12. If lockout occurs, repeat steps 1 through 9.

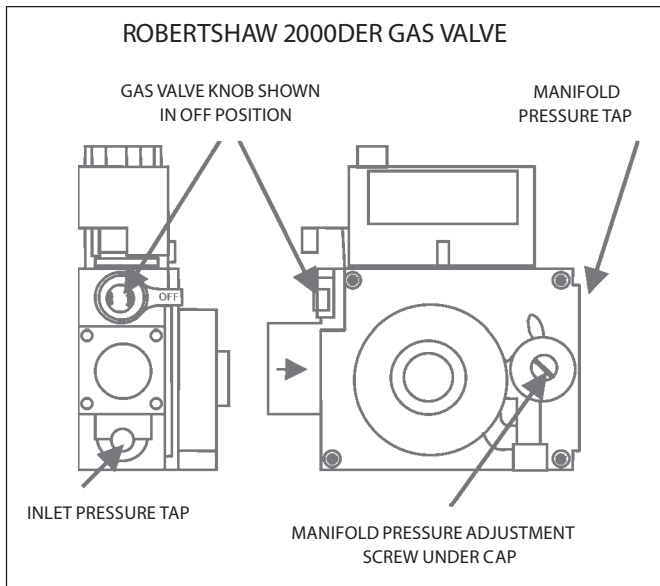

FIGURE 10

- If appliance still will not operate, follow the instructions "TO TURN OFF GAS TO UNIT" and call your service technician or gas supplier.

TO TURN OFF GAS TO UNIT

- Set thermostat to lowest level.
- Turn off all electrical power to unit if service is to be performed.
- Depress knob on gas valve; knob will snap to OFF.

HEATING SEQUENCE OF OPERATION

- When the thermostat calls for heat, the combustion air blower starts immediately.
- Combustion air pressure switch proves blower operation before allowing power to the ignition controller. This switch is factory set and no adjustment is necessary.
- After prepurge of approximately 30 seconds, the spark ignition is energized and the solenoid valves open in the gas valve.
- The spark then ignites the gas, the ignition sensor proves the flame and the combustion process continues.
- In the event that the flame is not detected after the first 10-second trial for ignition, the controller will repeat steps 3 and 4 an additional two times before locking out the gas valve. Ignition control will then automatically repeat steps 3, 4, and 5 after 60 minutes.

To interrupt the 60-minute lockout period, move thermostat from "Heat" to "OFF" then back to "HEAT." Heating sequence then restarts at step 1.

- The burners shall light without noticeable crossover delay. There shall be no flame lifting from the burner heads, flashback or burning within the burner. The flames shall be predominantly blue in color and shall be approximately centered in the tubes with no apparent impingement taking place.

- The ignition control will energize the fan approximately 45 seconds after ignition is established.
- After the thermostat demand is satisfied the gas valve is closed; 5 seconds after the demand is satisfied the combustion air blower is shut off.
- The control center shall shut off the system fan approximately 150 seconds after the gas valve is deenergized.

IGNITION CONTROL LED

The ignition control board contains a green LED which indicates the following:

TABLE 3
IGNITION CONTROL LED

LED	UNIT OPERATION
Slow Flash*	Normal Operation - No call for heat
Fast Flash	Normal Operation - Call for heat Current signal at FLAME terminal 0.6 to 1.0 microamps
2 Flashes	System lockout - failed to detect or sustain flame Current signal at FLAME terminal <0.6 microamps
3 Flashes	Pressure switch failed closed before CAB is energized or failed open after CAB is energized
4 Flashes	High limit or rollout switch open
5 Flashes	Flame sensed and gas valve not energized
Steady Off	Loss of power
Steady On	Ignition control failure

*When thermostat is placed in continuous fan mode LED will slowly flash.

GAS CONVERSION KIT OPTIONAL

Can be purchased at any Enerco / Mr. Heater dealer or direct from the factory under the following numbers

45NG--TO-- LP-----60067 75NG--TO-- LP-----60069
45LP---TO--NG-----60066 75LP---TO--NG-----60071

ADJUSTMENTS

HIGH ALTITUDE

Units may be fired at full input up to 2000 ft. (610m) above sea level. Above 2000 ft. (610m), manifold pressure must be adjusted on some units. Adjust pressure regulator to pressure shown in table 4 for natural gas and table 5 for LP/propane gas.

GAS FLOW

To check for proper gas flow to the combustion chamber, determine the Btu input from the appliance rating plate. Divide this input rating by the Btu per cubic feet of available gas. Result is the required number of cubic feet per hour. Determine the flow of gas through the gas meter for two minutes and multiply by 30 to get the hourly flow of gas.

GAS PRESSURE

- Check gas line pressure with unit firing at maximum rate. A

minimum of 5.0" w.c. for natural gas or 10.4" w.c. for LP/propane gas should be maintained for proper unit operation.

- After line pressure has been checked and adjusted, check manifold pressure. Correct manifold pressure is shown on the unit rating plate. See figure 10 for gas pressure adjustment screw location. A natural gas to LP/propane gas changeover kit is required to convert unit. Refer to installation instructions provided with changeover kit for conversion procedure.

LIMIT CONTROL

The limit control switch is factory set and not field adjustable.

TABLE 4

NATURAL GAS MANIFOLD PRESSURES - IN.WC. (KPA)

MHU45/75 HSU45/75	ALTITUDE FT. (M)	
	0-2000 (0-610)	2 000-4500 (610-1370)
45/75	4.0 (0.99)*	3.6 (0.89)
*No adjustment required.		

TABLE 5

LP/PROPANE GAS MANIFOLD PRESSURES - IN.WC. (KPA)

MHU45/75 HSU45/75	ALTITUDE FT. (M)	
	0-2000 (0-610)	2 000-4500 (610-1370)
45/75	10 (2.49)*	8.0 (1.99)
*No adjustment required.		

LOUVER VANE ADJUSTMENTS

Rotate louver vanes to direct airflow upward, downward, straight, or any combination of these directions. When unit is installed in an inverted position, louvers may be positioned in the same manner.

COMBUSTION AIR PRESSURE SWITCH

This pressure switch checks for proper combustion air blower operation before allowing an ignition trial. The switch is factory set and no field adjustment is necessary.

FLAME ROLLOUT SWITCH

The flame rollout switch(es) are located on the burner box top, behind the ignition control board. This normally closed switch opens on a temperature rise. Check for adequate combustion air before manually resetting switch.

SERVICE

CAUTION Turn off gas and electrical power to unit before performing any maintenance or service operations on this unit. Remember to follow lighting instructions when putting unit back into operation after service or maintenance.

If any of the original wire as supplied with the appliance must be replaced, it must be replaced with wiring material having a temperature rating of at least 105°C.

Do not use this appliance if any part has been under water. Immediately call a qualified service technician to inspect the appliance and replace any gas control which has been under water.

BURNERS

- Periodically examine burner flames for proper appearance during the heating season.
- Before each heating season examine the burners for any deposits or blockage that may have occurred.
- Clean burners as follows:
 - Turn off both electrical and gas supplies to unit.
 - Disconnect gas supply piping, high tension and sensor leads. Remove gas manifold. Remove burner tray.
 - Clean burners as necessary. Make sure that burner heads line up properly to ensure flame crossover. Check spark gap on electrode and adjust if required. The gap should be between 0.110 inch and 0.140 inch (2.79mm to 3.56mm). The gap may be checked with appropriately sized twist drills or feeler gauges.
 - Reinstall burner tray, gas manifold, high tension and sensor leads. Reconnect gas supply piping.
 - Restore electrical power and gas supply. Follow lighting instructions to light unit. Check burner flame.

FLUE PASSAGEWAY AND FLUE BOX

The flue passages and flue box should be inspected and cleaned prior to each heating season. The sequence of operation should be as follows:

- Turn off both electrical and gas supply to unit.
- Disconnect combustion air blower wiring.
- Remove screws securing flue box to unit. Remove flue box. If necessary, remove blower assembly from flue box. Clean flue box with wire brush.
- Remove turbulator retention bracket and turbulators. Clean turbulators with wire brush.
- Remove burners as described in section "BURNERS" section.
- Clean tubes with a wire brush.
- Reassemble unit. The combustion air and flue box gaskets should also be replaced during reassembly.
- Restore electrical power and gas supply. Follow lighting instructions to light unit. Check operation of unit.

WIRING SCHEMATIC FOR UNITS WITH 6-PIN CONNECTOR SCN-KWC CONTROL BOARD

△ MAXIMUM LOAD NOT TO EXCEED 20VA AT 24V, CLASS 2.

DISCONNECT ALL POWER BEFORE SERVICING.
FOR PROPER GROUNDING, REFER TO LOCAL CODES

KEY	DESCRIPTION
A3	COMPONENT
A3	CONTROL BLURER, IGNITION
B3	MOTOR, FAN
B3	MOTOR, COMBUSTION AIR BLOWER
BV1	VALVE, GAS
S10	LIMIT, PRIMARY GAS
S18	SWITCH, COMB. AIR BLWR PRONE
(1)S47	SWITCH-FLAME ROLLOUT 1
(2)S47	SWITCH-FLAME ROLLOUT 2
T1	TRANSFORMER, CONTROL

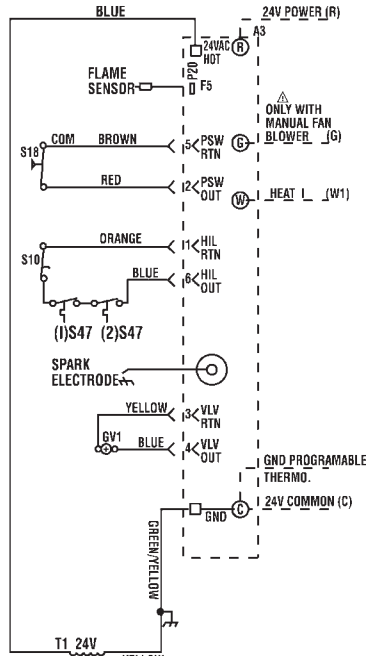

NOTE: IF ANY OF THE ORIGINAL WIRE AS SUPPLIED WITH THE APPLIANCE MUST BE REPLACED, IT MUST BE REPLACED WITH WIRING MATERIAL HAVING A TEMPERATURE RATING OF AT LEAST 105C.

WARNING-
ELECTRIC SHOCK HAZARD. CAN CAUSE INJURY OR DEATH. UNIT MUST BE GROUNDING IN ACCORDANCE WITH NATIONAL AND LOCAL CODES.

SET THERMOSTAT HEAT ANTICIPATION ROBERTSHAW VALVE..... .4

WIRE DIAGRAM	
GAS FIRED UNIT HEATER DSI-IGNITION	
MHU45LP	MHU45NG
HSU45LP	HSU45NG
MHU75LP	MHU75NG
HSU75LP	HSU75NG
60006	REV.

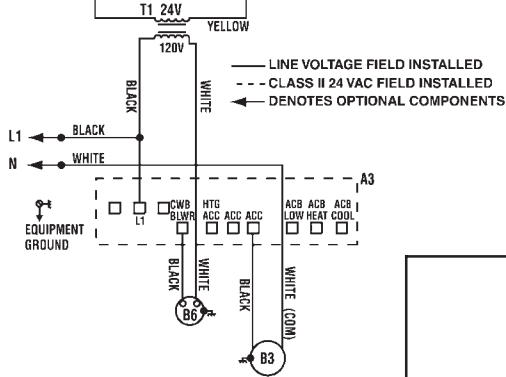

LADDER DIAGRAM

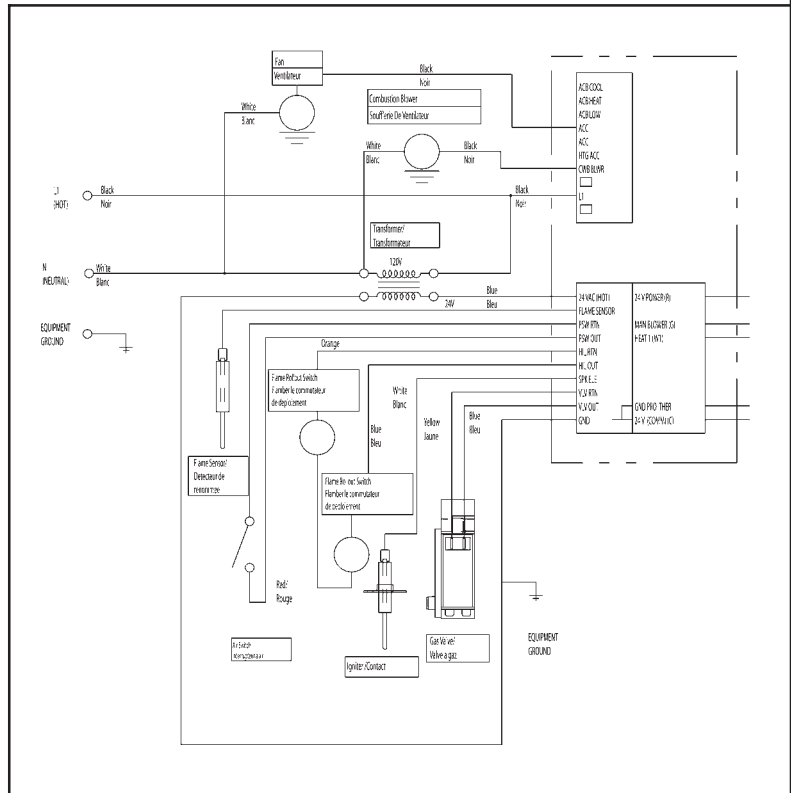

COMBUSTION AIR BLOWER

Under normal operating conditions, the combustion air blower should be checked and cleaned prior to the heating season with the power supply disconnected. Use a small brush to clean blower wheel.

ELECTRICAL

1. Check all wiring for loose connections.
2. Check for correct voltage at unit (unit operating).
3. Check amperage draw.

FLUE AND CHIMNEY

Check all vent and vent connector joints for tightness. Ensure that connections are sealed and that there are no blockages.

FAILURE TO OPERATE

If unit fails to operate check the following:

1. Is thermostat calling for heat?
2. Is main disconnect closed?
3. Is there a breaker tripped or a fuse blown?
4. Is gas turned on at meter?
5. Is manual shutoff valve open?
6. Is unit ignition system in lock out? If unit locks out again, call service technician to inspect unit.
7. Is pressure switch closed? Obstructed flue will cause unit to shut off at pressure switch. Check flue passage and outlet.

REPAIR PARTS

When ordering repair parts include the complete unit model number listed on the unit rating plate. For example: MHU45/75 and HSU45/75.

PARTS LIST:

SEE BACK PAGE FOR PARTS ORDERING INFORMATION

REF #.	DESCRIPTION	45 ITEM #	QUANTITY	75 ITEM #	QUANTITY
1	CIRCUIT BOARD.....	60105	1	S/A	1
2	LIMIT SENSOR.....	60015	1	S/A	1
3	ELECTRODE IGNITER.....	60035	1	S/A	1
4	ELECTRODE SENSOR	60040	1	S/A	1
5	BURNER	60050	3	S/A	5
6	IGNITION LEAD	60045	1	S/A	1
7	SENSOR LEAD	60046	1	S/A	1
8	ORIFICE (NAT)	60049	3	S/A	5
9	ORIFICE (LP)	60056	3	S/A	5
10	GAS VALVE (NAT)	02812	1	S/A	1
11	GAS VALVE (LP)	02811	1	S/A	1
12	TRANSFORMER	60025	1	S/A	1
13	PRESSURE SWITCH	60030	1	S/A	1
14	HI LIMIT SENSOR HEAT EXCH.	60022	1	S/A	1
15	PRESSURE SWITCH TUBE	60031	1	S/A	1
16	INDUCED DRAFT MOTOR	60020	1	S/A	1
17	VENT ADAPTER	60130	1	60140	1
18	INDUCED DRAFT MOTOR GASKET	60135	1	S/A	1
19	BACK BRACKET	60075	1	S/A	1
20	FRONT BRACKET	60080	1	S/A	1
21	LOUVERS	60100	5	S/A	7
22	LOUVER SPRING	60103	5	S/A	7
23	FLUE BOX	60085	1	60087	1
24	FLUE BOX GASKET	60090	1	60092	1
25	HEAT EXCHANGER	60065	1	60068	1
26	ACCESS DOOR	60070	1	60072	1
27	FRONT	60095	1	60097	1
28	SIDE DOOR	60110	1	60112	1
29	WRAPPER	60115	1	60117	1
30	FAN MOTOR	60055	1	60054	1
31	FAN GUARD	60120	1	60122	1
32	FAN ASSEMBLY	60125	1	60127	1

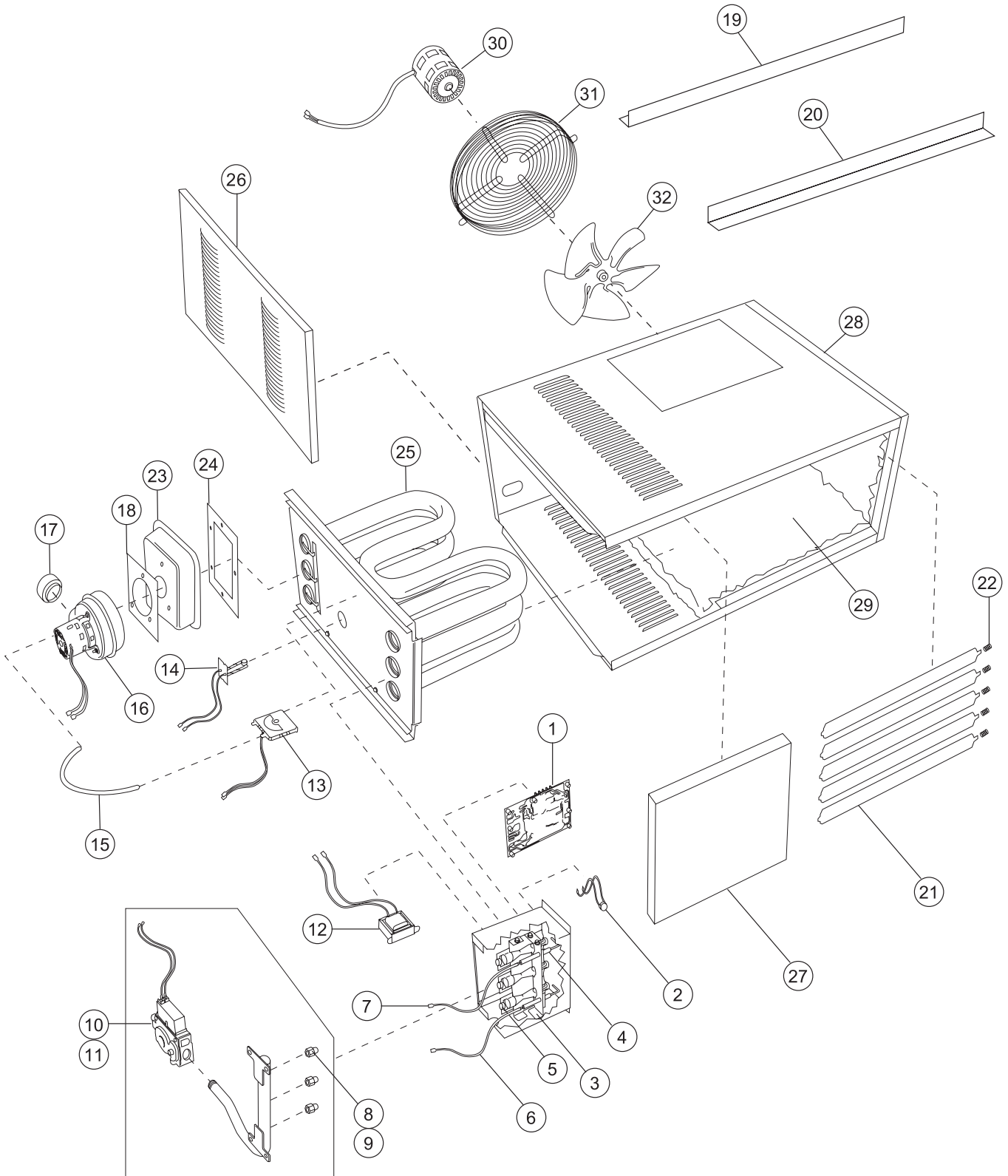

OPERATING INSTRUCTIONS AND OWNER'S MANUAL

MR. HEATER

READ INSTRUCTIONS CAREFULLY: Read and follow all instructions. Place instructions in a safe place for future reference. Do not allow anyone who has not read these instructions to assemble, light, adjust or operate the heater.

HEATSTAR

MODEL

MHU 45
MHU 75

MODEL

HSU 45
HSU 75

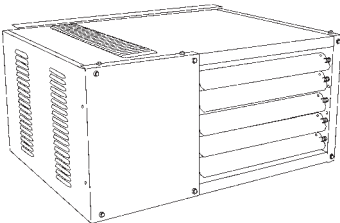

WARNING:

USE ONLY MANUFACTURER'S REPLACEMENT PARTS. USE OF ANY OTHER PARTS COULD CAUSE INJURY OR DEATH. REPLACEMENT PARTS ARE ONLY AVAILABLE DIRECT FROM THE FACTORY AND MUST BE INSTALLED BY A QUALIFIED SERVICE AGENCY.

PARTS ORDERING INFORMATION:

PURCHASING: Accessories may be purchased at any Enerco / Mr. Heater local dealer or direct from the factory
FOR INFORMATION REGARDING SERVICE
 Please call Toll-Free 800-251-0001 • www.mrheater.com
 Our office hours are 8:30 AM – 5:00 PM, EST, Monday through Friday.
 Please include the model number, date of purchase, and description of problem in all communication.

LIMITED WARRANTY

The company warrants this product to be free from imperfections in material or workmanship, under normal and proper use in accordance with instructions of The Company, for a period of three years on parts (limited) and 10 years on the heat exchanger, from the date of delivery to the buyer. The Company, at its option, will repair or replace products returned by the buyer to the factory, transportation prepaid within said period and found by the Company to have imperfections in material or workmanship.

If a part is damaged or missing, call our Technical Support Department at 800-251-0001.

Address any Warranty Claims to the Service Department, Enerco Group, Inc., 4560 W. 160TH ST., CLEVELAND, OHIO 44135. Include your name, address and telephone number and include details concerning the claim. Also, supply us with the purchase date and the name and address of the dealer from whom you purchased our product.

The foregoing is the full extent of the responsibility of the Company. There are no other warranties, express or implied. Specifically there is no warranty of fitness for a particular purpose and there is no warranty of merchantability. In no event shall the Company be liable for delay caused by imperfections, for consequential damages, or for any charges of the expense of any nature incurred without its written consent. The cost of repair or replacement shall be the exclusive remedy for any breach of warranty. There is no warranty against infringement of the like and no implied warranty arising from course of dealing or usage of trade. This warranty will not apply to any product which has been repaired or altered outside of the factory in any respect which in our judgment affects its condition or operation.

Some states do not allow the exclusion or limitation of incidental or consequential damages, so the above limitation or exclusion may not apply to you. This Warranty gives you specific legal rights, and you may have other rights which vary from state to state.

Enerco Group, Inc. reserves the right to make changes at any time, without notice or obligation, in colors, specifications, accessories, materials and models.



ANS Z83.8-(2002) • CSA 2.6-(2002)
UNIT HEATER

CSA .10.96 U.S. (2ND ED.)
UNIT HEATER FOR RESIDENTIAL INSTALLATION
CATEGORY/CATEGORIE I

ENERCO GROUP, INC., 4560 W. 160TH ST., CLEVELAND, OHIO 44135 • 216-916-3000
 Mr. Heater is a registered trademarks of Enerco Group, Inc.
 © 2003, Enerco/Mr. Heater . All rights reserved